

2010 FORMULA TWO TECHNICAL REGULATIONS

SUMMARY

ARTICLE 1 : DEFINITIONS

- 1.1 F2
- 1.2 Sporting Regulations
- 1.3 Event
- 1.4 Set-up Sheet
- 1.5 Test
- 1.6 F2 Technical Manual

ARTICLE 2 : GENERAL PRINCIPLES

- 2.1 Validity
- 2.2 Changes to the Regulations
- 2.3 Compliance with the Regulations
- 2.4 Car build
- 2.5 Duty of a competitor
- 2.6 Modifications to the car
- 2.7 Measurements
- 2.8 Disputes over the Regulations
- 2.9 Doubt over the meaning of the Regulations

ARTICLE 3 : ELIGIBLE CARS

- 3.1 Rolling chassis
- 3.2 Authorisation to modify a car
- 3.3 Replacing car components

ARTICLE 4 : ENGINES

- 4.1 Permitted engines
- 4.2 Repairs to engines
- 4.3 Engine seals
- 4.4 Change of engines
- 4.5 ECU/GCU control

ARTICLE 5 : BODYWORK AND DIMENSIONS

- 5.1 Conformity with dimensions
- 5.2 Skid block
- 5.3 Permitted changes to the original specification

ARTICLE 6 : WEIGHT

- 6.1 Weight of the car
- 6.2 Ballast
- 6.3 Replacing parts during a race

ARTICLE 7 : REPAIRS

- 7.1 Repairs to non-structural components
- 7.2 Repairs to brake ducts
- 7.3 Repairs to the monocoque

ARTICLE 8 : DATA ACQUISITION

- 8.1 Telemetry systems
- 8.2 Data acquisition systems

- 8.3 Data acquisition system specification
- 8.4 Sensors and wiring
- 8.5 Disconnecting or removing sensors
- 8.6 Defective sensors
- 8.7 Data recording

ARTICLE 9 : ELECTRICAL SYSTEM

- 9.1 Modifications to the electrical system

ARTICLE 10 : GEARBOX AND TRANSMISSION TO THE WHEELS

- 10.1 Gear ratios
- 10.2 Modifications to the transmission system
- 10.3 Reverse gear

ARTICLE 11 : SUSPENSION AND STEERING

- 11.1 Suspension settings

ARTICLE 12 : OIL AND WATER SYSTEMS

- 12.1 Modifications to the oil or water system

ARTICLE 13 : BRAKES

- 13.1 Modifications to the braking system

ARTICLE 14 : WHEELS AND TYRES

- 14.1 Modifications to the wheels
- 14.2 Tyre supplier
- 14.3 Tyre marking
- 14.4 Tyre allocation

ARTICLE 15 : COCKPIT

- 15.1 Permitted changes to the original specification

ARTICLE 16 : FUEL AND LUBRICANTS

- 16.1 Supply of fuel and lubricants
- 16.2 Fuel or oil additives
- 16.3 Fuel cooling
- 16.4 Fuel analysis

ARTICLE 17 : SAFETY EQUIPMENT AND DRIVER INSTALLATION

- 17.1 Safety regulations
- 17.2 Safety belts
- 17.3 Safety belt fixings
- 17.4 Seat shell
- 17.5 Seat shell padding
- 17.6 Extractable seat
- 17.7 Clearance to the driver's head
- 17.8 Driver knee test
- 17.9 Drivers leaving the cockpit
- 17.10 Rear light

ARTICLE 18 : ON-BOARD TELEVISION CAMERAS

- 18.1 Fitting of cameras or dummy cameras
- 18.2 Position of cameras equipment
- 18.3 Position of cameras or dummy cameras

ARTICLE 19 : TIMING TRANSPONDERS

- 19.1 Fitting of timing transponders

ARTICLE 1 : DEFINITIONS

1.1 F2 :

Formula Two Limited, the organiser of the FIA Formula Two Championship.

1.2 Sporting Regulations :

The [2010](#) FIA Formula Two Sporting Regulations

1.3 Event :

Any event entered into the FIA F2 Championship Calendar for any year commencing at the scheduled time for scrutineering and sporting checks and including all practice and the races themselves and ending at the later of the time for the lodging of a protest under the terms of the International Sporting Code and the time when a technical or sporting verification has been carried out under the terms of the Code.

1.4 Set-up Sheet :

The set-up sheet produced by F2 specifying the set up of the car for any Event or Test, including what adjustments may be made to the car at that Event or Test.

1.5 Test :

Official tests available for the championship competitors.

1.6 F2 Technical Manual :

The operating manual published by F2 in conjunction with the car's designers containing technical data on the F2 car and methods, techniques and regimes for adjusting and operating the car.

ARTICLE 2 : GENERAL PRINCIPLES

2.1 These Technical Regulations will be valid for a minimum of one year beginning on the first of January [2010](#).

2.2 Changes to the Technical Regulations will be published by the FIA and communicated to the competitors by means of technical directives. Changes will become applicable on the dates indicated by the FIA according to the Code.

2.3 All cars must comply with these regulations in their entirety at all times during an Event or Test.

2.4 All cars must be built and operated in accordance with the relevant sections of the F2 Technical Manual [and the set-up sheet](#).

2.5 It is the duty of each competitor to satisfy the FIA technical delegate and the stewards of the meeting that his car complies with these regulations in their entirety at all times during an Event.

2.6 All modifications which are not expressly authorised in these Technical Regulations or subsequent technical directives are forbidden.

2.7 All measurements must be made while the car is stationary on a flat horizontal surface.

2.8 Should any dispute arise as to the eligibility and/or compliance of any entered car, F2 will supply any element or knowledge deemed necessary for the purpose of scrutineering in order that comparative checking may be undertaken in order to prove conformity with the original design.

2.9 In event of doubt concerning any element of these Technical Regulations, competitors are entitled to seek written clarification from the FIA. All such questions and their responses will be circulated to all the competitors. All such responses will be considered as the official understanding of the relevant regulation and therefore used by the FIA technical delegate as a complement to the regulation itself.

ARTICLE 3 : ELIGIBLE CARS

3.1 The only rolling chassis permitted are those manufactured by MSV under the specification Williams JPH1, the [2010](#) F2 Car. Once supplied, no parts may be modified in any way whatsoever except by F2 after consultation with the FIA or, if necessary, the designers. Any such modifications will only be permitted if they are deemed absolutely necessary after a problem has been clearly identified.

- 3.2 Unless authorisation is specifically given or a modification is imposed within these Technical Regulations no element may be added to nor removed from the original car specification. The original design and construction of the car must be preserved at all time.
- 3.3 Any components supplied as part of the rolling chassis or gearbox which need to be replaced can only be replaced by parts supplied by F2 and these parts can only be fitted by authorised F2 personnel.

ARTICLE 4 : ENGINE

- 4.1 The only engines permitted are the engines supplied by F2. Once supplied, the engine and ancillaries supplied with it may not be modified in any way except by the nominated F2 engine supplier.
- 4.2 Any revision, repair or change to the engine can only be carried out by the nominated F2 engine supplier.
- 4.3 The engine will be delivered with security seals in place and these must remain intact from delivery until the engine is returned to the engine supplier for any revision or repair.
- 4.4 In the event of an engine being required by the stewards of the meeting in order to determine compliance with the regulations during the course of an Event, F2 will surrender the engine to the FIA technical delegate. Under these circumstances, F2 will be obliged to install another engine in the competitor's car. The use of this spare engine will be at no cost to the competitor.
- 4.5 ECU/GCU control :
- The ECU will be supplied by F2 with the original security seals in place, these seals must remain intact.
 - In accordance with the general timetable for the Event, and as required at other times, the F2 engine supplier will communicate with the ECU in order to allow the data download and the upload of the appropriate software parameters. These parameters will be the same for all engines at all times.
 - If a malfunction of an ECU is suspected by either F2 or the F2 engine supplier, either may communicate with or exchange the ECU at any time.

ARTICLE 5 : BODYWORK AND DIMENSIONS

- 5.1 Cars must conform to the dimensions laid out in Appendix 1 at all times.
- 5.2 The skid plank fitted under the chassis facing the ground must have at all time a thickness of 6mm +/- 1mm as defined in Appendix 2. In order to establish the conformity of the skid block after use, its thickness will only be measured using the holes located as shown in Appendix 2.
- 5.3 **Permitted changes to the original specification:**
- 5.3.1 The front wing flap orientation may be changed, but only from the range of adjustments specified in the F2 Technical Manual.
- 5.3.2 The rear upper wing **and main plain** angle and configuration may be changed, but only from the range of adjustments specified in the F2 Technical Manual. Gurney flaps may be added or removed from the upper and lower rear wing elements as defined in the Set-up Sheet.
- 5.3.3 Front and rear brake ducts may be partially or fully covered with black tape for the sole purpose of optimising brake temperatures.
- 5.3.4 Tape may be applied to fasteners or any vulnerable leading edges. In all cases it must be clear that the tape has no function other than securing the fixings or protecting the parts to which it is attached. The specification for this is defined in Appendix 3.
- 5.3.5 With regard to the height of the undertray and undertray skirt, the following are the dimensions shown on Appendix 4 of the Technical Regulations:
- A mm from the reference plane (Z0) to the bottom of the undertray skirt;

- 30 mm from the reference plane (Z0) to the underneath surface of the undertray.
- Dimension A and the profile of the underside of the floor will be verified using an FIA template and these checks may be carried out at any time during the Event.

The value of dimension A will be published on the Set-up Sheet prior to the start of each Event. The above dimensions must be considered as minimum values and respected for each side of the car at all times.

However, with regard to the dimensions outlined above, and only these dimensions, a tolerance of 2mm will be allowed in order to cover all potential for discrepancy such as, but not limited to :

- component manufacturing and repair tolerances ;
- imperfection of chassis bottom flatness ;

ARTICLE 6 : WEIGHT

- 6.1** At all times during an Event the weight of the car with the driver aboard wearing his complete racing apparel must not be less than the minimum weight stipulated on the Set-up Sheet issued by F2 prior to each Event or Test.
- 6.2** Ballast required to achieve the minimum weight may only be attached using the specific fixing points provided on the car. It must also be possible to fix tamper-proof seals if deemed necessary by the stewards of the meeting or FIA technical delegate.
- 6.3** With the exception of nitrogen or compressed air, no substance may be added to the car during the race. If it becomes necessary to replace any part of the car during the race, the new part must not weigh any more than the original part.

ARTICLE 7 : REPAIRS

- 7.1** Minor repairs to non structural components such as side pods and main bodywork may be made by F2 for the competitor provided the damage does not affect an area greater than 75mm at its maximum dimension and does not affect a fixing or fixing area. In all other cases damaged components must be replaced.
- 7.2** Very minor repairs to brake ducts may be made provided the damage does not affect an area greater than 75mm at its maximum dimension. In all other cases damaged brake ducts must be replaced.
- 7.3** Any repairs to the survival cell, nosebox or rear impact structure must be carried out by F2 and its approved suppliers.

ARTICLE 8 : DATA ACQUISITION

- 8.1** Telemetry systems are forbidden.
- 8.2** The data acquisition system must only be operated by F2.
- 8.3** The data acquisition system specification can only be altered by F2.
- 8.4** The only sensors and wiring permitted for data are those provided by F2 as part of the original car.
- 8.5** Disconnecting or removing any sensor fitted to the car as part of the original data acquisition system and listed in the F2 Technical Manual is forbidden except where it is carried out by authorised F2 personnel.
- 8.6** Defective sensors connected with the original data acquisition must be replaced prior to the next session or race.
- 8.7** F2 will record and retain all data from the data acquisition system of each car from the first Test to the last Event of the current season. Copies of all such data must be made available to the FIA technical delegate if deemed necessary and may be used for scrutineering purposes.

ARTICLE 9 : ELECTRICAL SYSTEM

- 9.1** Modifications to the original electrical system are forbidden.

ARTICLE 10 : GEARBOX AND TRANSMISSION TO THE WHEELS

- 10.1 All cars will have the same ratio sets fitted at any given Event or Test. The ratios for any Event or Test will be stipulated in the Set-up Sheet.
- 10.2 No other gearbox or transmission modifications are permitted.
- 10.3 All cars must have a reverse gear operable any time during an Event or Test by the driver when the engine is running.

ARTICLE 11 : SUSPENSION AND STEERING

11.1 Suspension settings :

The following suspension settings may be changed provided the adjustments are within the range specified on the Set-up Sheet, the adjustment method is as specified by F2 and that measurements of the settings are taken at the locations specified by F2 :

- Camber angles may be adjusted at the front and rear of the car.
- The free travel of the third element (heave spring assembly) on the front suspension.
- Rear bump rubber free travel.
- Adjustment of shock absorbers is free using the range available on the original part.
- Adjustment of front anti-roll bar is free using the range available on the original part.
- The rear anti-roll bar may be selected from the F2 specified component range or it may be disconnected.
- Tracking may be adjusted at the front and rear of the car.
- Any other permitted adjustments to the suspension will be specified on the Set-up Sheet

ARTICLE 12 : OIL AND WATER SYSTEMS

- 12.1 No modifications to the oil and water systems are permitted.

ARTICLE 13 : BRAKES

- 13.1 No modifications to the braking system are permitted.

ARTICLE 14 : WHEELS AND TYRES

- 14.1 No modifications to the wheels are permitted.
- 14.2 Only tyres provided by the official tyre supplier may be used during Events or Tests. This applies to both wet and dry-weather tyres.
- 14.3 All tyres which are to be used at an Event or Test will be marked with a unique identification by the official manufacturer. The use of tyres without the appropriate identification is strictly forbidden.
- 14.4 The allocation of the tyres to each car will be determined by the FIA technical delegate.

ARTICLE 15 : COCKPIT

15.1 Permitted changes to the original specification:

- Pedal position, pedal pads, master cylinder pushrod length and the relative working angles may be changed for driver comfort. The original pedal arms as supplied by the car manufacturer must not be modified.
- The type and position of the driver's heel or foot rest are free.
- A screen no higher than 40mm may be added at the front of the cockpit.

ARTICLE 16 : FUEL AND LUBRICANTS

- 16.1 Fuel and lubricants will all be supplied to all competitors by F2 to a uniform specification.

- 16.2 No fuel or oil additives may be used.
- 16.3 The use of any device on board or off the car to decrease the temperature of the fuel is forbidden.
- 16.4 The scrutineers may take fuel samples for analysis at any time during an Event or Test following the FIA Formula One fuel sampling procedure but by removing the engine cover and using the dry-break on the return from the fuel rail to the tank as the sampling point.

ARTICLE 17 : SAFETY EQUIPMENT AND DRIVER INSTALLATION

- 17.1 Cars must comply with the requirements of Articles 14.1, 14.2, 14.3, 14.4, 14.6, 14.8, and 14.9 of the [2010](#) FIA Formula One Technical Regulations at all times during a race Event or Test.
- 17.2 The safety belts supplied with the car may not be changed for another type.
- 17.3 The safety belt fixing system to the monocoque may not be changed or modified.
- 17.4 The seat shell positioning system must not be modified.
- 17.5 Padding and minor modifications of the seat shell are allowed for driver's comfort providing all the functionality of the seat and its safety equipment is preserved.
- 17.6 An extraction test may be requested at any time by the FIA technical delegate. The seat must be removable without the need to cut or remove any of the seat belts.
- 17.7 When seated normally with his seat belts fastened, the driver's helmet must be at least at 70mm below a line drawn between the highest points of the front and rear roll structures.
- 17.8 In order to ensure that the driver's head is not unduly exposed and for him to maintain good lateral visibility he must, when seated normally and looking straight ahead with his head as far back as possible, have his eye visible when viewed from the side.
- 17.9 The driver, seated normally with his seat belts fastened and with the steering wheel removed must be able to raise both legs together so that his knees are past the plane of the steering wheel in the rearward direction. This action must not be prevented by any part of the car.
- 17.10 From his normal seating position, with all seat belts fastened and whilst wearing his usual driving equipment the driver must be able to remove the steering wheel and get out of the car within five seconds and then replace the steering wheel in a total of ten seconds. For this test, the position of the steered wheels will be determined by the FIA technical delegate and after the steering wheel has been replaced steering control must be maintained.
- 17.11 No less than 85 % of the rear light LEDs must be in order to work at the beginning of every session or race.

ARTICLE 18 : ON-BOARD TELEVISION CAMERAS

- 18.1 Competitors may be required to carry either camera(s) and camera electronic equipment or a dummy camera and camera dummy electronic equipment at all times during Events and Tests.
- 18.2 The position of the camera electronic equipment or dummy camera electronic equipment will be determined by F2 and cannot be changed.
- 18.3 The position on the car of the on-board camera(s) will be determined by F2 and approved by the scrutineers.

ARTICLE 19 : TIMING TRANSPONDERS

- 19.1 All cars must be fitted with a timing transponder supplied by the officially appointed timekeepers. This transponder must be fitted in strict accordance with the instructions of the timekeepers.

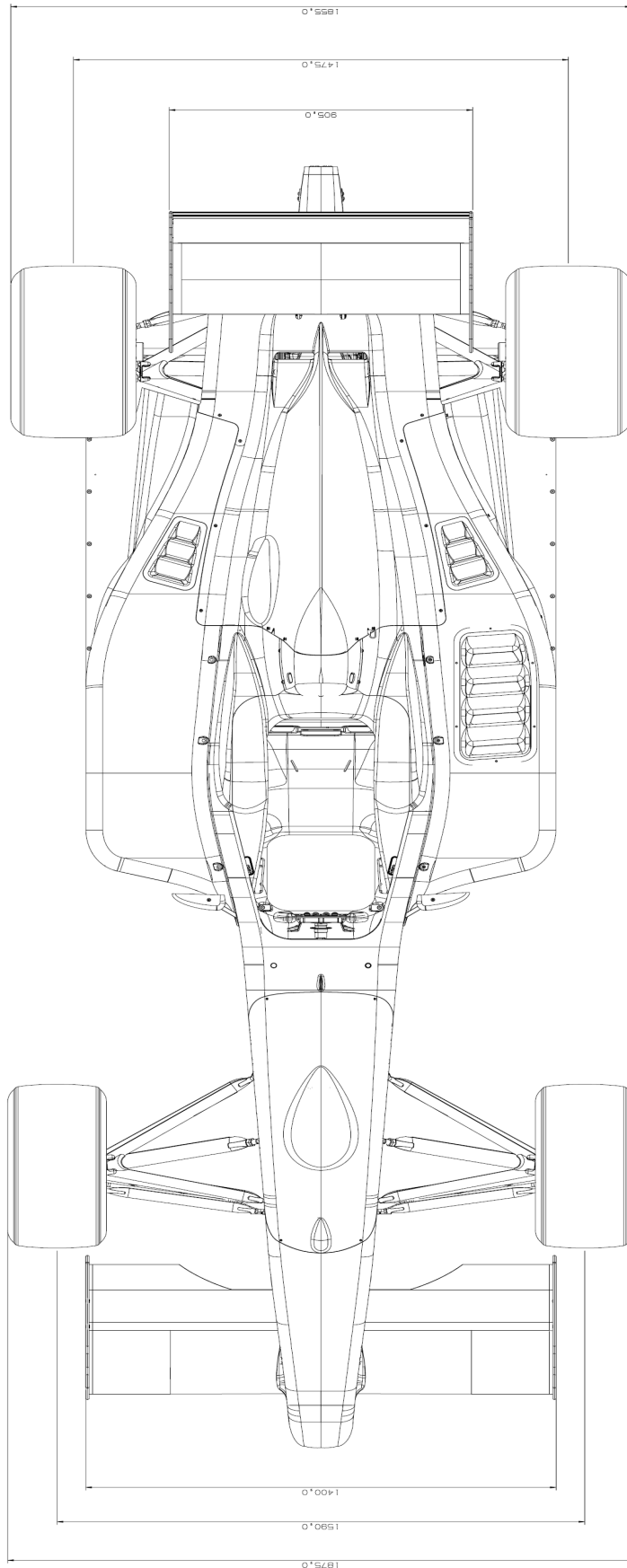

APPENDIX 2

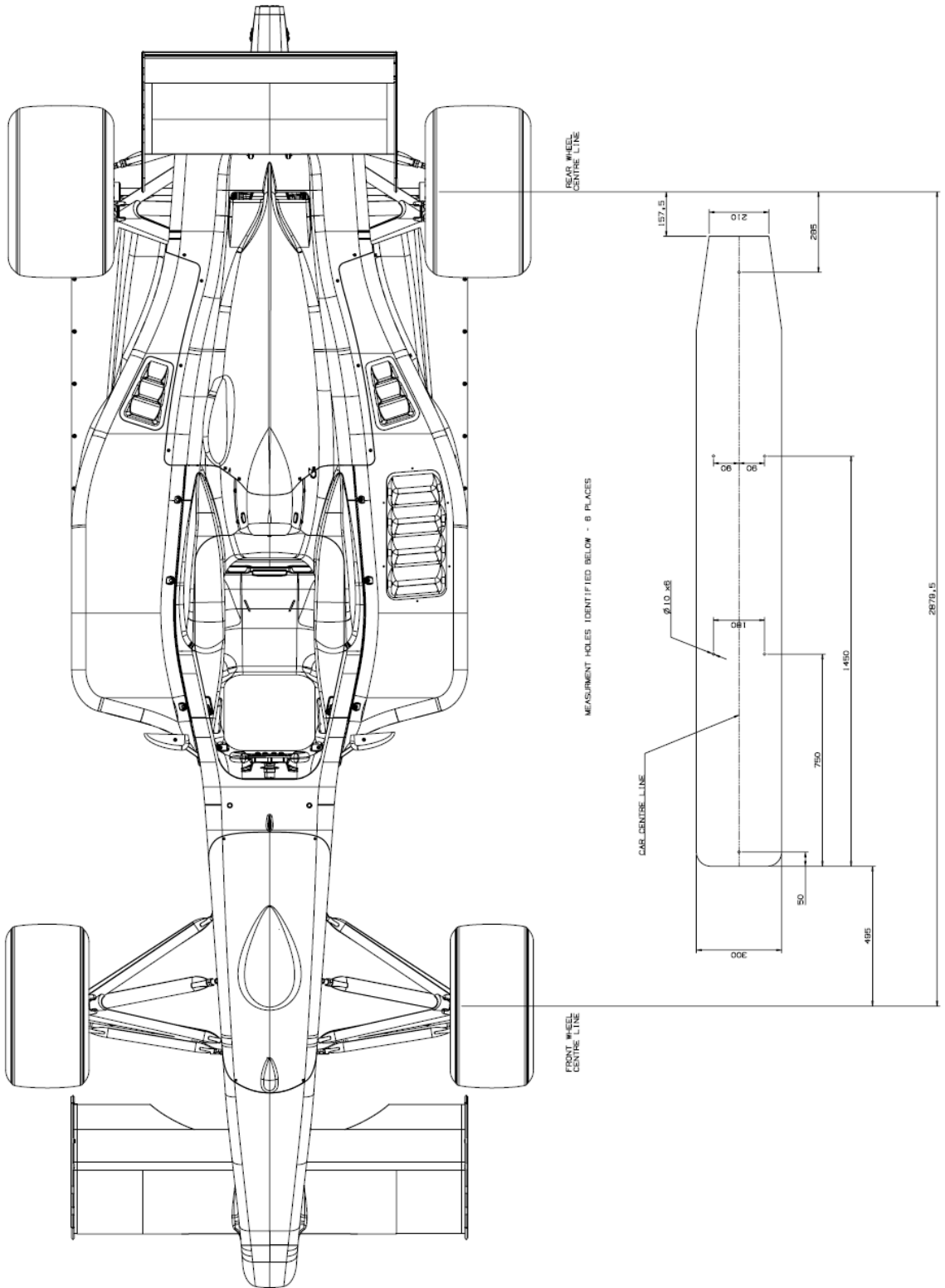

APPENDIX 3

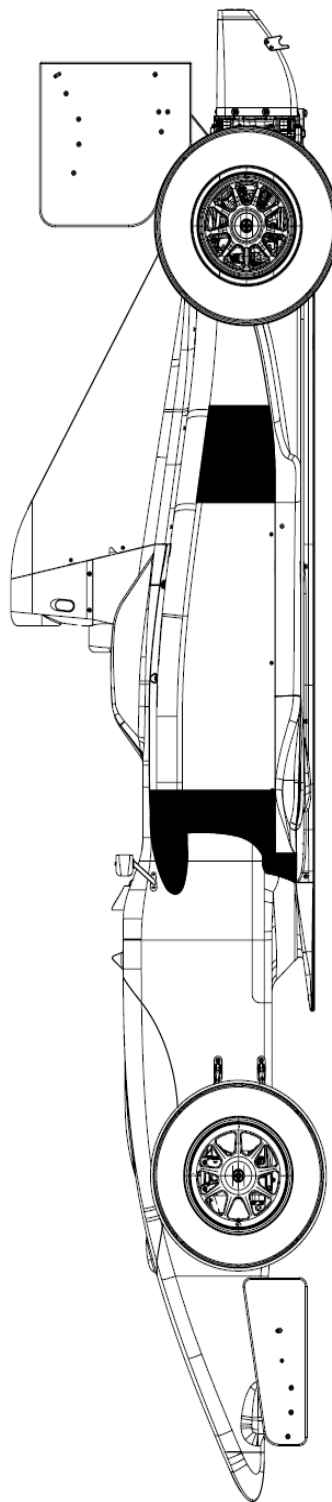
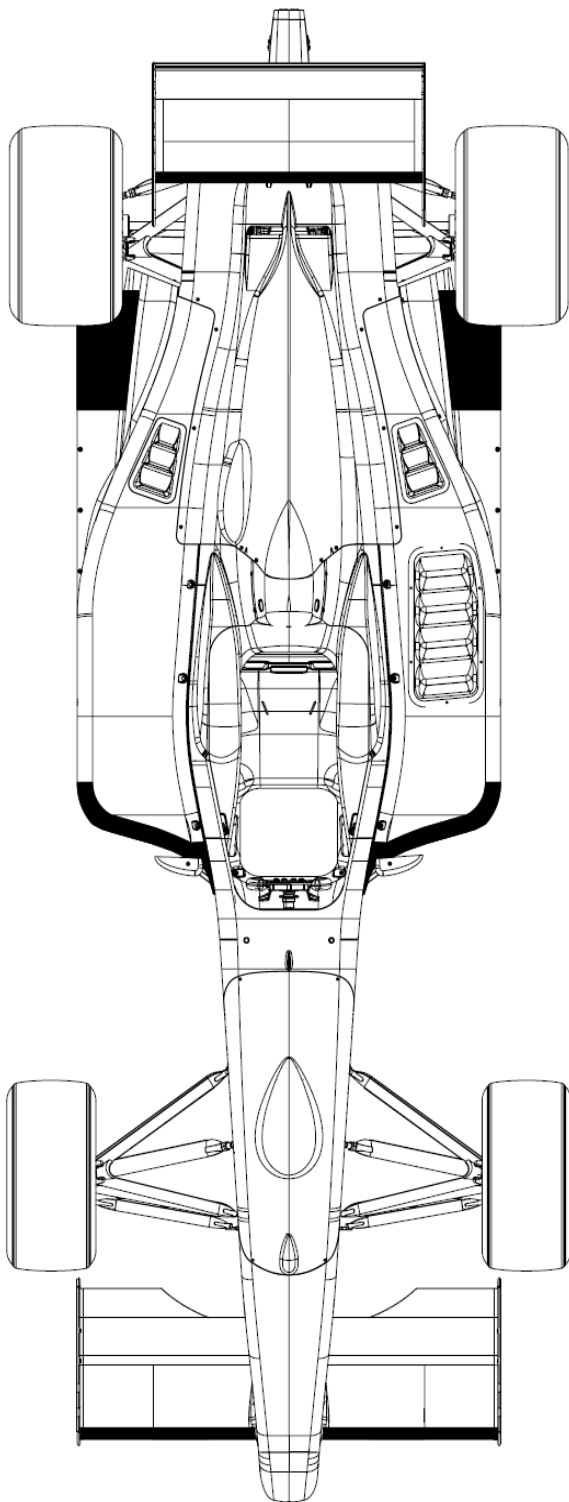

■ = AREAS WHERE PROTECTIVE TAPE MAY BE APPLIED TO BODYWORK

APPENDIX 4

